



TITAN FLOW CONTROL, INC.

CHECK VALVE ♦ WAFER TYPE ♦ DUAL DISC

ANSI CLASS 150 ♦ CARBON AND STAINLESS STEEL

MODELS: CV 42-CS
(CARBON STEEL)

CV 42-SS
(STAINLESS STEEL)

SIZES: 2" ~ 24"



2" ~ 6" PROVIDE DUAL PRESSURE
SERVICE (ANSI CLASS 150/300)

FEATURES

- ◇ **COST EFFICIENT DESIGN**
LOW WEIGHT AND SHORT LAYING LENGTH PRODUCE SAVINGS IN INITIAL COST, SPACE REQUIREMENTS, AND INSTALLATION WHEN COMPARED TO FULL-BODY, SWING-TYPE CHECK VALVES.
- ◇ **MINIMAL HEAD LOSS**
CONTOUR OF BODY PROVIDES A SHORT AND STRAIGHT FLOW PATH THAT GENERATES VERY LITTLE TURBULENCE. ADDITIONALLY, THE SPRING-LOADED DISCS ARE DESIGNED WITH VERY LOW CRACKING PRESSURE WHICH REDUCES THE AMOUNT OF ENERGY REQUIRED TO OPEN THE VALVE.
- ◇ **QUICK CLOSURE TO REDUCE WATER HAMMER**
SHUT-OFF IS ACHIEVED VIA THE FULLY AUTOMATIC, SPRING-ASSISTED DISCS THAT CLOSE NEAR ZERO FLOW VELOCITY. THE LIGHTWEIGHT, SPLIT DISC DESIGN CREATES A POSITIVE SHUTOFF PRIOR TO FLOW REVERSAL AND HELPS TO KEEP SLAMMING AND SURGES TO A MINIMUM.
- ◇ **DESIGNED FOR LONG SERVICE LIFE**
THE SPRING AND DISCS ARE DESIGNED TO ALLOW THE DISCS TO LIFT LINEARLY BEFORE PIVOTING TO AVOID THE DISC HEEL FROM SCRUBBING THE SEALING SURFACE. ALSO, DISCS ARE EQUIPPED WITH CAST-IN SHOCK BUMPERS THAT HELP TO REDUCE WEAR AND TEAR ON INTERNAL COMPONENTS.
- ◇ **FUGITIVE EMISSION DESIGN**
THE RETAINER-LESS BODY DESIGN ELIMINATES POTENTIAL LEAK PATHS TO THE ENVIRONMENT SO THERE ARE NO BODY EMISSIONS.
- ◇ **RESILIENT AND METAL SEATS**
BOARD, LAPPED SEALING SURFACE (METAL) MEETS OR EXCEEDS API 598 TEST REQUIREMENTS. RESILIENT SEATS (VITON/BUNA) ENSURE A BUBBLE TIGHT SEAL.

TECHNICAL

PRESSURE/TEMPERATURE RATING
CS - ASTM A216 GR. WCB - CLASS 150

WOG: 285 PSI @ 100 °F

PRESSURE/TEMPERATURE RATING
SS - ASTM A351 GR. CF8M - CLASS 150

WOG: 275 PSI @ 100 °F

SEAT MATERIAL
TEMPERATURE RANGE

VITON: -40 ~ 400 °F
BUNA-N: -20 ~ 250 °F

SPRING MATERIAL ⁽¹⁾
TEMPERATURE MAXIMUM

T-316 SS: 250 °F
Inconel X-750: 1000 °F

1. For higher temperatures, Inconel springs must be specified. Stainless steel material is standard for carbon steel units and Inconel X-750 is standard for stainless steel units.

APPLICATIONS

MARKETS: WATER & WASTEWATER, PULP & PAPER, CHEMICAL & PETROCHEMICAL, POWER, PETROLEUM AND OIL & GAS

BUNA-N PROPERTIES: MOST WIDELY USED ELASTOMER. GOOD FOR MOST PETROLEUM OILS AND FLUIDS, SILICONE GREASES AND OILS, AND COLD WATER. EXCELLENT COMPRESSION SET, TEAR, AND ABRASION RESISTANCE. POOR WEATHER RESISTANCE AND MODERATE HEAT RESISTANCE. NOT RECOMMENDED FOR SEVERE OZONE-RESISTANT APPLICATIONS.

VITON PROPERTIES: OFFERS A BROAD RANGE OF CHEMICAL RESISTANCE AND EXCELLENT HEAT RESISTANCE. GOOD MECHANICAL PROPERTIES AND COMPRESSION SET RESISTANCE. OFTEN USED IN APPLICATIONS WHERE NOTHING ELSE WILL WORK. FAIR LOW TEMPERATURE RESISTANCE AND LIMITED HOT-WATER RESISTANCE AND SHRINKAGE.

The above data represents common market and service applications. No representation or guarantee, expressed or implied, is given due to the numerous variations of concentrations, temperatures and flow conditions that may occur during actual service.

TITAN FLOW CONTROL, INC.

YOUR PIPELINE TO THE FUTURE!

Tel: 910-735-0000 ♦ Fax: 910-738-3848 ♦ titan@titanfci.com ♦ www.titanfci.com
290 Corporate Drive ♦ PO Box 7408 ♦ Lumberton, NC 28358



TITAN FLOW CONTROL, Inc.

290 Corporate Drive
Lumberton, NC 28358
Tel: 910.735.0000

E-mail: titan@titanfci.com
Web: www.titanfci.com
Fax: 910.738.3848

CHECKVALVE • WAFER TYPE • DUAL DISC

**MODELS: CV 42-CS (Carbon Steel)
CV 42-SS (Stainless Steel)**

ANSI Class
150 lb

BILL OF MATERIALS (1)

No.	PART	CV 42-CS (3)	CV 42-SS
1	Body	Carbon Steel A216 Gr.WCB	Stainless Steel A351 Gr. CF8M
2	Seat (2)	Metal/Viton/Buna-N (4)	Metal or Viton (4)
3	Disc (2)	Stainless Steel A351 Gr. CF8M	Stainless Steel A351 Gr. CF8M
4	Spring (2)	Stainless Steel	Inconel X-750
5	Shaft	Stainless Steel A276 Gr. 316	Stainless Steel A276 Gr. 316
6	Cap	Carbon Steel ASTM A105	Stainless Steel A351 Gr. CF8M

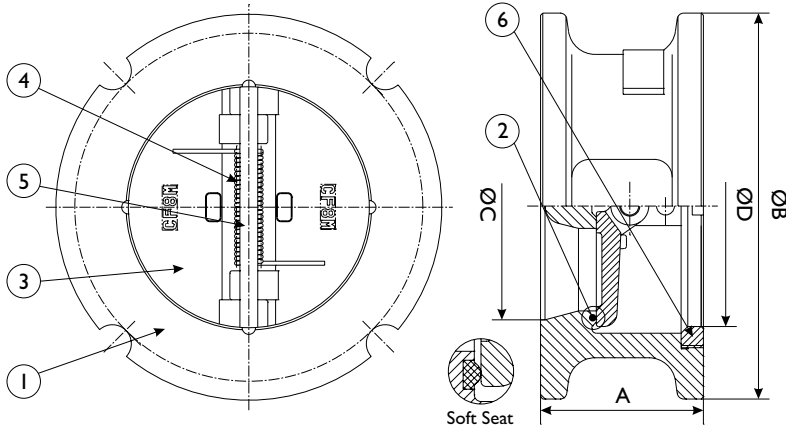

1. Bill of Materials represents standard materials. Equivalent or better materials may be substituted at the manufacturer's discretion.
2. Denotes recommended spare parts.
3. Carbon Steel bodies are epoxy painted.
4. Metal seat is stainless steel inlay.

CAD illustration is representative of sizes 2" through 6". Sizes 8" through 24" are not scalloped. Sizes 2" through 6" are designed for dual pressure service (ANSI Class 150 and 300).

DIMENSIONS AND PERFORMANCE DATA (1)

SIZE	in	2	2 1/2	3	4	5	6	8	10	12	14	16	18	20	24
	mm	50	65	80	100	125	150	200	250	300	350	400	450	500	600
A DIMENSION FACE TO FACE	in	2.38	2.62	2.88	2.88	3.88	3.87	5.00	5.75	7.12	7.25	7.50	8.00	8.62	8.75
	mm	60	67	73	73	99	99	127	146	181	184	191	203	219	222
ØB DIMENSION OVERALL DIAMETER	in	4.33	5.04	5.78	7.05	8.43	9.81	10.91	13.27	16.02	17.64	20.15	21.54	23.78	28.15
	mm	110	128	147	179	214	249	277	337	407	448	512	547	604	715
ØC DIMENSION INLET DIAMETER	in	2.00	2.50	3.00	4.00	5.00	6.00	8.00	10.00	12.00	13.26	15.24	17.24	19.50	23.42
	mm	51	64	76	102	127	152	203	254	305	337	387	438	495	595
ØD DIMENSION OUTLET DIAMETER	in	2.16	2.67	3.23	4.25	5.12	6.38	8.66	10.63	12.60	13.78	15.75	17.24	19.50	23.42
	mm	55	68	82	108	130	162	220	270	320	350	400	438	495	595
ASSEMBLED WEIGHT	lb	5.5	8.0	10.0	15.5	23.5	36.0	51.5	88.0	138.0	164.0	242.0	276.0	340.0	536.0
	kg	2.5	3.6	4.5	7.0	10.6	16.3	23.3	39.9	62.5	74.3	109.7	125.1	154.1	242.9
Flow Coefficient	C _v	62	110	175	350	550	850	1500	2400	3700	5400	8250	10400	14200	23000
Cracking Pressure (2)	psi	≤ .25	≤ .25	≤ .25	≤ .25	≤ .25	≤ .25	≤ .25	≤ .25	≤ .25	≤ .25	≤ .25	≤ .25	≤ .25	≤ .25

1. Dimensions and weights are for reference only. When required, request certified drawings.
2. Cracking pressure is for horizontal installations only. For vertical installations, please consult factory.

PRESSURE - TEMPERATURE RATINGS (1)

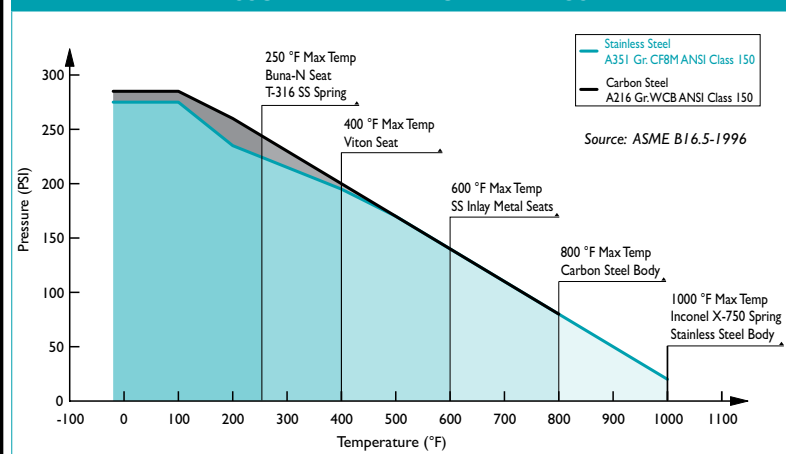

1. The above chart displays the pressure-temperature ratings for the valve's body material per ASME B16.5-1996. Max temperature limits have been added for seat and spring materials. For ANSI Class 300 ratings (2" ~ 6"), please refer to the CV 44-CC/SS specification sheet.

REFERENCED STANDARDS & CODES

CODE	DESCRIPTION
ANSI/API 594	Valve Design and Manufacture
ANSI/ASME 16.5	Flange Dimensions
ANSI/API 594	Valve Face to Face Dimensions
API 598	Valve Inspection and Pressure Test

PRESSURE - TEMPERATURE RATING

Body Material	A216 Gr.WCB	A351 Gr. CF8M
WOG (water, oil, gas):	285 PSI @ 100 °F	275 PSI @ 100 °F

Sizes 2" through 6" are designed for dual pressure service (Class 150 and 300). For ANSI Class 300 ratings, please refer to the CV 44-CC/SS specification sheet.

SEAT AND SPRING TEMPERATURE RATING

Seat Material	Range	Spring Material	Max
VITON:	-40 ~ 400 °F	T-316 SS:	250 °F
BUNA-N:	-20 ~ 250 °F	INCONEL X-750:	1000 °F

Ordering Code: _____ Size: _____

Customer/Project: _____

Inq./P.O. No.: _____

Titan Order No.: _____

Certified By: _____ Date: _____

Engineering Specification Submittal

Titan FCI makes every effort to ensure the information presented on our literature accurately reflects exact product specifications. However, as changes occur, there may short-term differences between actual product specifications and the information shown on our literature. Titan FCI reserves the right to make specification changes to improve our products without prior notification.

Wafer Type - Check Valve - Dual Disc • Models: CV 42-CS/SS

Size	Model Number	Description	Drawing Number